

CH1500,CH2000

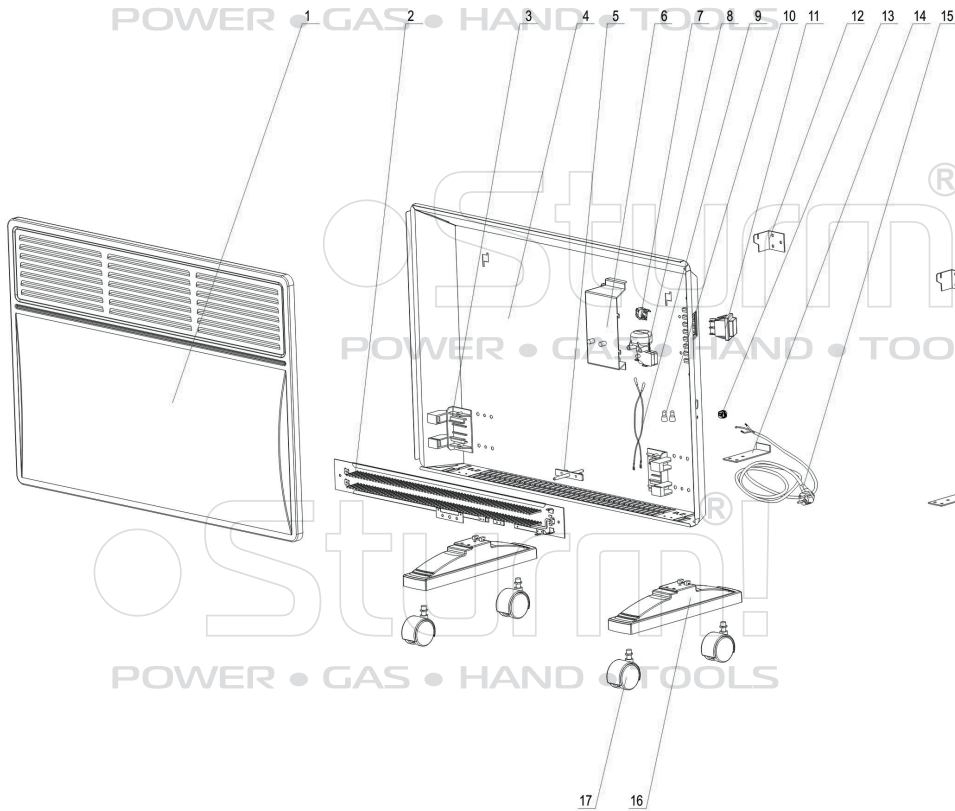

NO.	DESCRIPTION
1	FRONT SHELL
2	HEATING ELEMENT
3	BRACKET
4	BACK SHELL
5	LIMIT ROD
6	SWITCH BOX
7	THERMAL CUT-OUT
8	TIP-OVER SWITCH
9	INTERNAL WIRE
10	WIRE CONNECTOR
11	SWITCH
12	HOOK
13	WIRE CLAMP
14	STRUTTING PIECE
15	POWER CORD WITH PLUG
16	BOOT FOOT
17	CASTOR

ST20140328